

FEATURES AND BENEFITS

- Increased locking security for use in robust applications - includes high shock and vibration environments
- Light weight, robust aluminum profile
- Snag-resistant gasket curb enhances EMI integrity
- 1.0mm thick face for robust connector retention and grounding
- Custom cutouts included or board I/O
- The perfect solution to insure AMC's and uTCA boards remain secure in high shock and vibration applications



MicroTCA / AMC

FRONT PANEL ASSEMBLIES



SPECIFICATIONS

Panels - Aluminum with retention flanges

M3 Captive Screws - Stainless steel and zinc chromate over steel

Dual Light Pipe - (On front panel configurations only) Polycarbonate

EMI Gasket - Fabric over foam

Overlay - 0.25mm velvet matte polycarbonate for aesthetic appearance

Specification Compliance - PICMG uTCA Rel 1.0; UL94-VO; RoHS Compliant

MOUNTING HOLE LOCATIONS

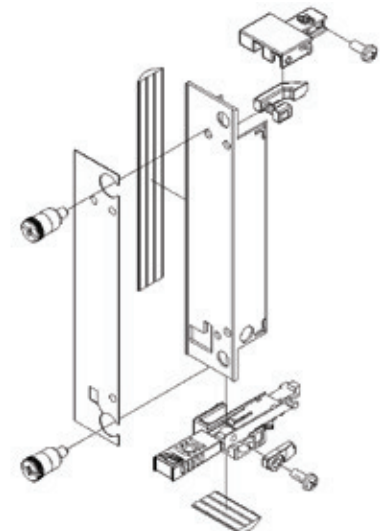
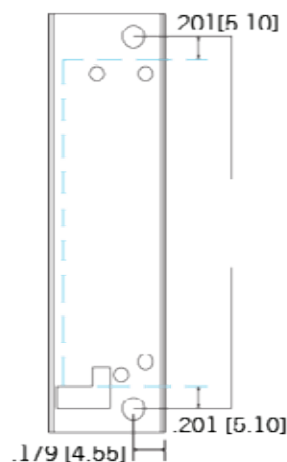

MicroTCA / AMC

FRONT PANEL ASSEMBLIES

AVAILABLE CONFIGURATIONS

- Compact, Mid-Size and Full-Size
- Single and Double Width
- Customize with I/O Cutouts and Labeling to Meet Your Application Requirements
- Filler Panel Configurations also Available to Complete Your System Requirements

FRONT PANEL SELECTION GUIDE

HEIGHT	WIDTH	MATERIAL	FINISHING
Single	Compact	Aluminum	Chromate with Optional Overlay
Single	Midsize	Aluminum	Chromate with Optional Overlay
Single	Full-Size	Aluminum	Chromate with Optional Overlay
Double	Compact	Aluminum	Chromate with Optional Overlay
Double	Mid-Size	Aluminum	Chromate with Optional Overlay
Double	Full-Size	Aluminum	Chromate with Optional Overlay

FRONT PANEL ASSEMBLIES

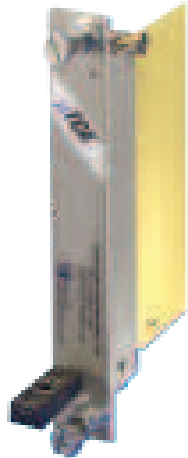

AMC Single Compact Assembly

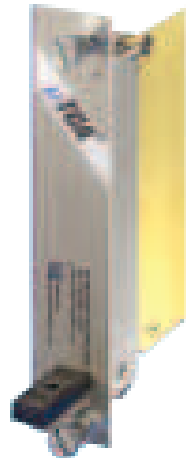

AMC Single Mid-Size Assembly

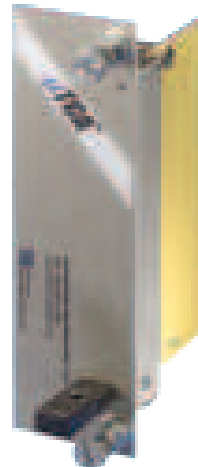

AMC Single Full-Size Assembly

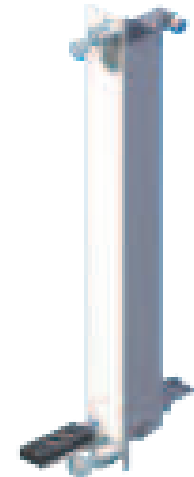

AMC Double Compact Assembly

WARRANTY

This product has a one year warranty.

CONTACT INFORMATION

www.atrenne.com
sales@atrenne.com
508.588.6110 or 800.926.8722

The information in this document is subject to change without notice and should not be construed as a commitment by Atrenne, a Celestica company. While reasonable precautions have been taken, Atrenne assumes no responsibility for any errors that may appear in this document. All products shown or mentioned are trademarks or registered trademarks of their respective owners.

